

ASSEMBLY INSTRUCTIONS:

SHUSH30+ Corner Assembly Instructions

TIME REQUIRED:

30 minutes

TOOLS REQUIRED:

Screwdriver, Electric Drill, Pencil, Measuring tape/Ruler, Spirt Level Required

*Tools are not included.

SKILL REQUIRED:

Easy ●●●●○ Hard

The Assembly Skill Rating is a 5-point system that shows the degree of effort needed in assembling a specific product. With 1 being easy for the average person and 5 requiring an expert. For most products, two persons are recommended.

NOTE

- As this is a commercial product, some intermediate skills may be required.
 - No pre-drill holes or markings are provided on our table or desk tops.
 - Please check you have all hardware before assembling.
- If you are missing any hardware, please contact your Rapidline reseller. Please ensure you have the name of the item, required hardware part and quantity.
 - Please retain your receipt as proof of purchase to validate your warranty.
- Assemble on a clean, flat, smooth surface such as a rug or carpet to avoid parts from being scratched.
 - Remove all wrapping materials, including staples and packing straps before you start to assemble
 - Keep all hardware parts out of reach of children.



CAUTION

- Heavy product. Do not attempt to lift or move without help
- Do not tighten screws and bolts until completely assembled.
- Do not use this product unless all bolts and screws are firmly secured and tightened.

WARNING

- If parts are missing, broken, damaged or worn stop using the product until all repairs are made.
 - Failure to follow these warnings could result in serious injury.

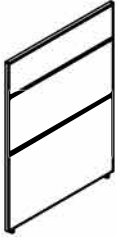
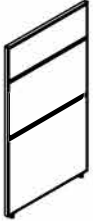
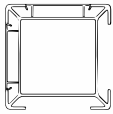
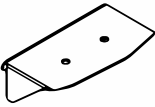
Part List

SEQ	PICTURE	MODEL	QTY	Remarks
1		IS1515 BL/GR	2x	
2		IS715 BL/GR	2x	
3		L 1500H Joining Pole	3x	
4				
5		Desk Brackets	10x	
6		4x16mm screw	40x	
7		T1515-75	1x	

IMPORTANT NOTE:

- Place all parts on a clean and smooth surface such as a rug or carpet to avoid the parts from being scratched.
- Check to be sure that you have all parts and hardware.
- Remove all wrapping materials, including staples & packing straps before you start to assemble.
- Don't tighten all screws/bolts until all completely assembled.
- Keep all hardware parts out of reach of children

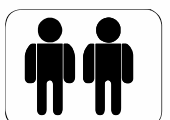



EASY Assembly
Without Tools

About 8 Mins
Assembly Time

STEP1

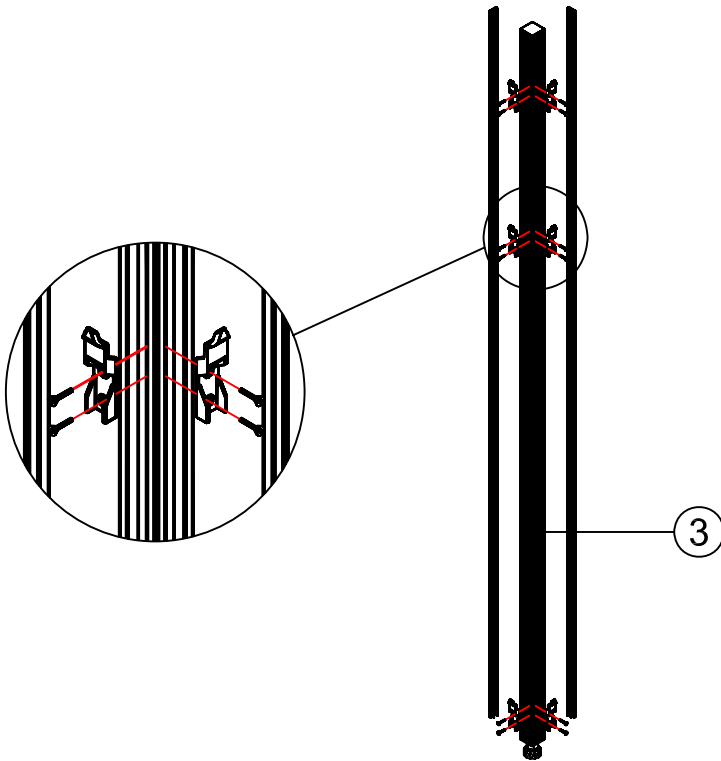

STEP2

Connect panel 1 to L joining Pole.

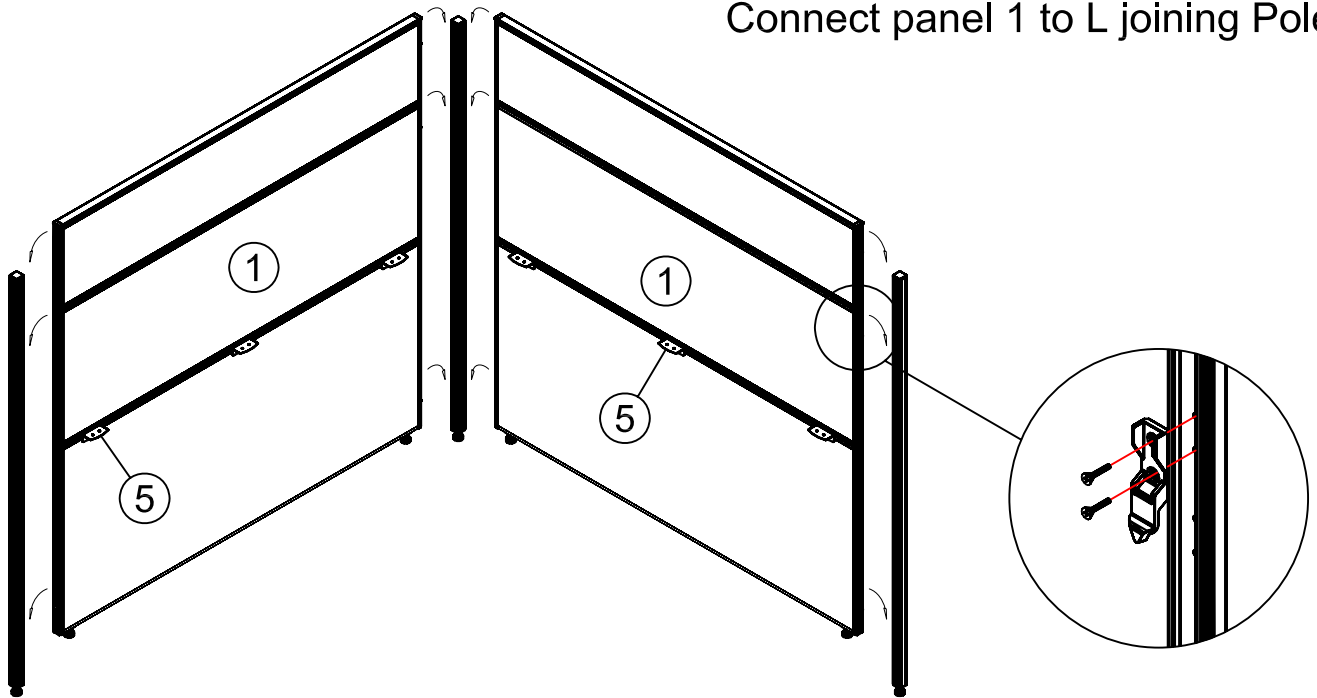

IMPORTANT NOTE:

- Place all parts on a clean and smooth surface such as a rug or carpet to avoid the parts from being scratched.
- Check to be sure that you have all parts and hardware.
- Remove all wrapping materials, including staples & packing straps before you start to assemble.
- Don't tighten all screws/bolts until all completely assembled.
- Keep all hardware parts out of reach of children

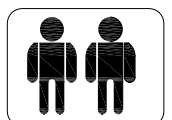



EASY Assembly
Without Tools

STEP3

Connect panel 2 to L joining Pole.

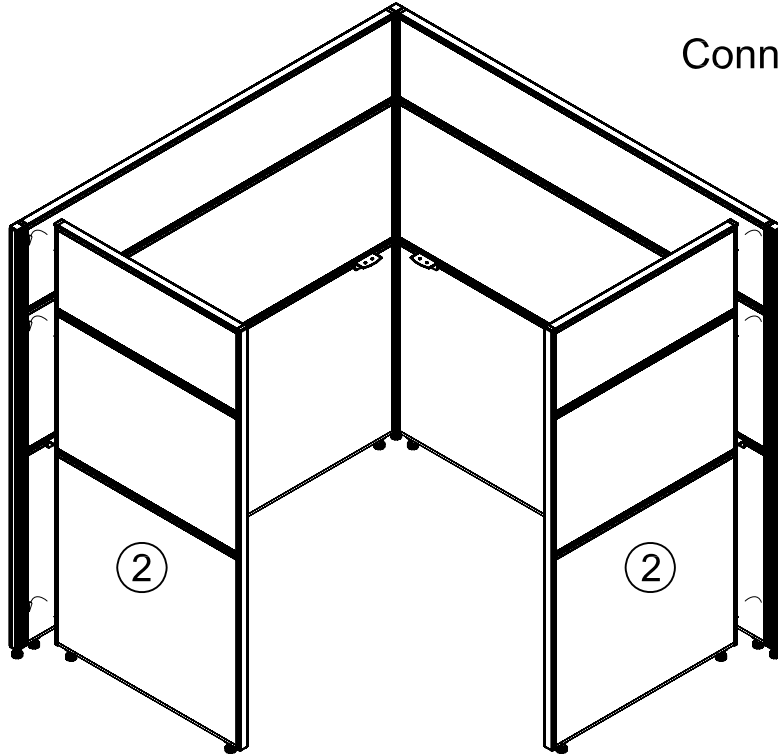

STEP4

Connect top 6 to panels using brackets.

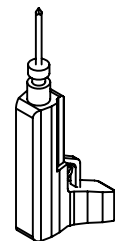
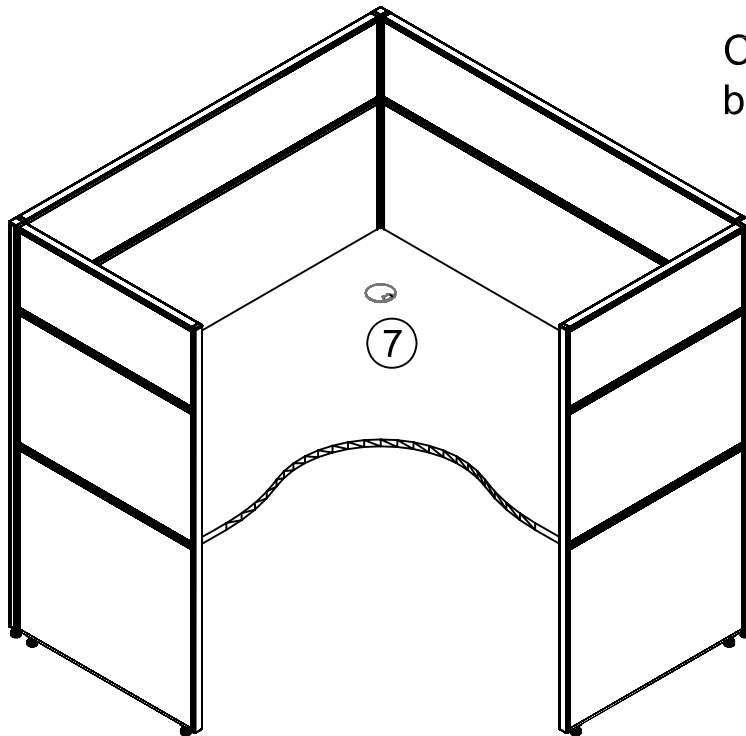

Notes: Use power drill to connect
desk top to brackets

IMPORTANT NOTE:

- Place all parts on a clean and smooth surface such as a rug or carpet to avoid the parts from being scratched.
- Check to be sure that you have all parts and hardware.
- Remove all wrapping materials, including staples & packing straps before you start to assemble.
- Don't tighten all screws/bolts until all completely assembled.
- Keep all hardware parts out of reach of children

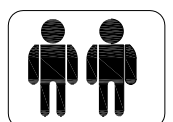



EASY Assembly
Without Tools

Part List

About 8 Mins
Assembly Time

SEQ	PICTURE	MODEL	QTY	Remarks
1		IS1515 BL/GR	3x	
2		IS715 BL/GR	4x	
3		L 1500H Joining Pole	2x	
4		T 1500H Joining Pole	2x	
5		Desk Brackets	20x	
6		4x16mm screw	80x	
7		T1515-75	2x	

STEP1

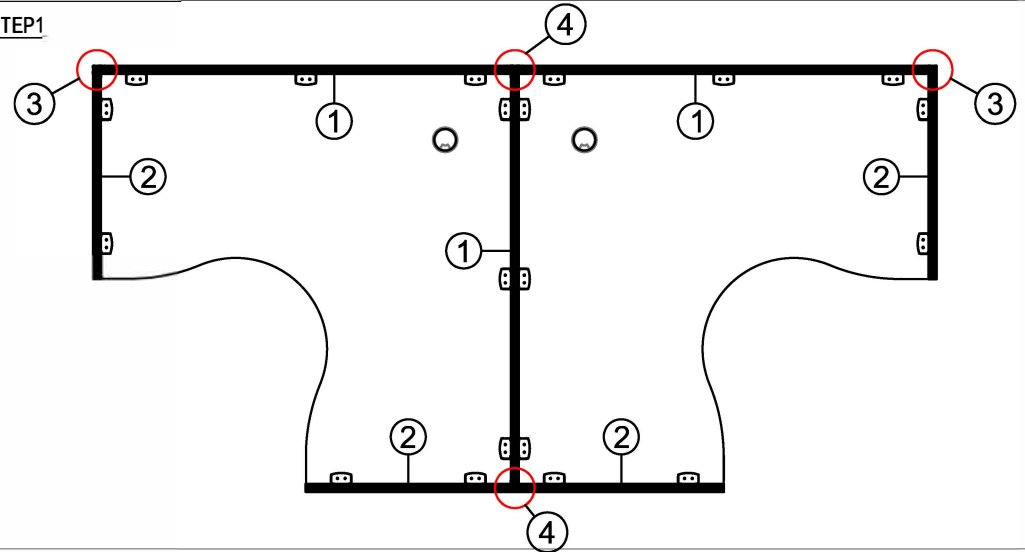

STEP2

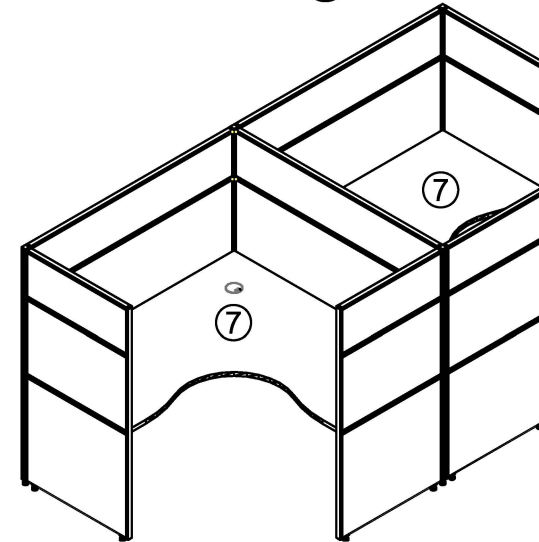

IMPORTANT NOTE:

- Place all parts on a clean and smooth surface such as a rug or carpet to avoid the parts from being scratched.
- Check to be sure that you have all parts and hardware.
- Remove all wrapping materials, including staples & packing straps before you start to assemble.
- Don't tighten all screws/bolts until all completely assembled.
- Keep all hardware parts out of reach of children



IMPORTANT NOTE:

- Place all parts on a clean and smooth surface such as a rug or carpet to avoid the parts from being scratched.
- Check to be sure that you have all parts and hardware.
- Remove all wrapping materials, including staples & packing straps before you start to assemble.
- Don't tighten all screws/bolts until all completely assembled.
- Keep all hardware parts out of reach of children

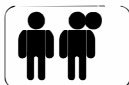



EASY Assembly
Without Tools

Part List

About 8 Mins
Assembly Time

SEQ	PICTURE	MODEL	QTY	Remarks
1		IS1515 BL/GR	4x	
2		IS715 BL/GR	8x	
3		T 1500H Joining Pole	4x	
4		+ 1500H Joining Pole	1x	
5		Desk Brackets	40x	
6		4x16mm screw	160x	
7		T1515-75	4x	

STEP1

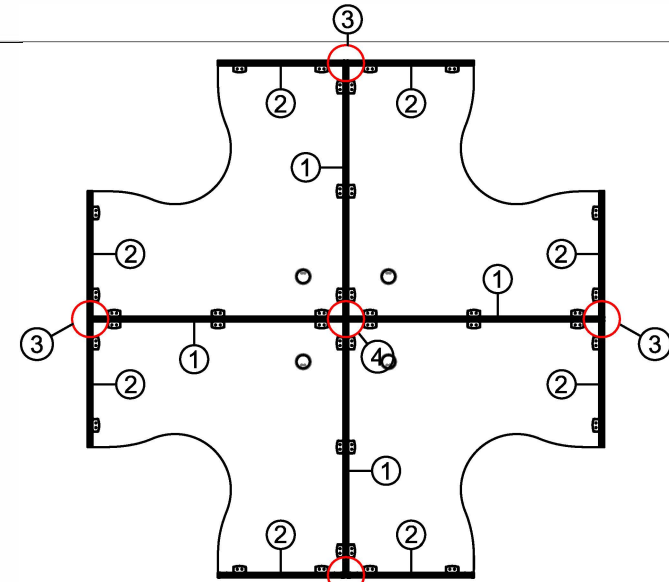

STEP2

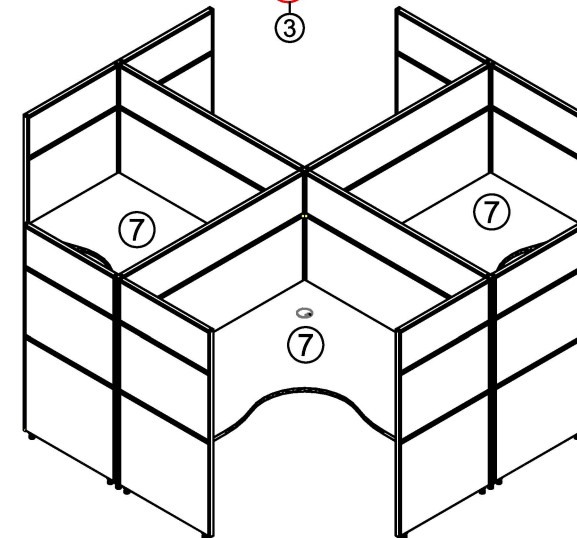

IMPORTANT NOTE:

- Place all parts on a clean and smooth surface such as a rug or carpet to avoid the parts from being scratched.
- Check to be sure that you have all parts and hardware.
- Remove all wrapping materials, including staples & packing straps before you start to assemble.
- Don't tighten all screws/bolts until all completely assembled.
- Keep all hardware parts out of reach of children



IMPORTANT NOTE:

- Place all parts on a clean and smooth surface such as a rug or carpet to avoid the parts from being scratched.
- Check to be sure that you have all parts and hardware.
- Remove all wrapping materials, including staples & packing straps before you start to assemble.
- Don't tighten all screws/bolts until all completely assembled.
- Keep all hardware parts out of reach of children

