

ASSEMBLY INSTRUCTIONS:

Product Code : GSL380

Product Name: GO Steel Lockers - Step Door

TIME REQUIRED:

35 minutes

TOOLS REQUIRED:

Pop Rivet Gun

*Tools are not included.

SKILL REQUIRED:

Easy  Hard

The Assembly Skill Rating is a 5-point system that shows the degree of effort needed in assembling a specific product. With 1 being easy for the average person and 5 requiring an expert. For most products, two persons are recommended.

NOTE

- As this is a commercial product, some intermediate skills may be required.
 - No pre-drill holes or markings are provided on our table or desk tops.
 - Please check you have all hardware before assembling.
- If you are missing any hardware, please contact your Rapidline reseller. Please ensure you have the name of the item, required hardware part and quantity.
 - Please retain your receipt as proof of purchase to validate your warranty.
- Assemble on a clean, flat, smooth surface such as a rug or carpet to avoid parts from being scratched.
- Remove all wrapping materials, including staples and packing straps before you start to assemble
 - Keep all hardware parts out of reach of children.

CAUTION

- Heavy product. Do not attempt to lift or move without help
- Do not tighten screws and bolts until completely assembled.
- Do not use this product unless all bolts and screws are firmly secured and tightened.

WARNING

- If parts are missing, broken, damaged or worn stop using the product until all repairs are made.
- Failure to follow these warnings could result in serious injury.

GSL380 ASSEMBLY INSTRUCTIONS

PART LIST

| Part No | Component | Quantity |
|---------|---|----------|
| 01 | Back | 01 |
| 02 | LH SIDE | 01 |
| 03 | RH SIDE | 01 |
| 04 | TOP | 01 |
| 05 | BOTTOM TRAY | 01 |
| 06 | Bottom Front | 01 |
| 07 | PARTITION SHELF | 02 |
| 08 | RH DOOR | 01 |
| 09 | LH DOOR | 01 |
| 10 | LOCKS | 02 |
| 11 | RIVETS 3.2X8 | 40 |
| 12 | RIVETS 4X8 <u>counter sunk for door</u> | 12 |
| 13 | COAT RAIL TOP (Longer) | 01 |
| 14 | COAT RAIL BOTTOM (Shorter) | 01 |

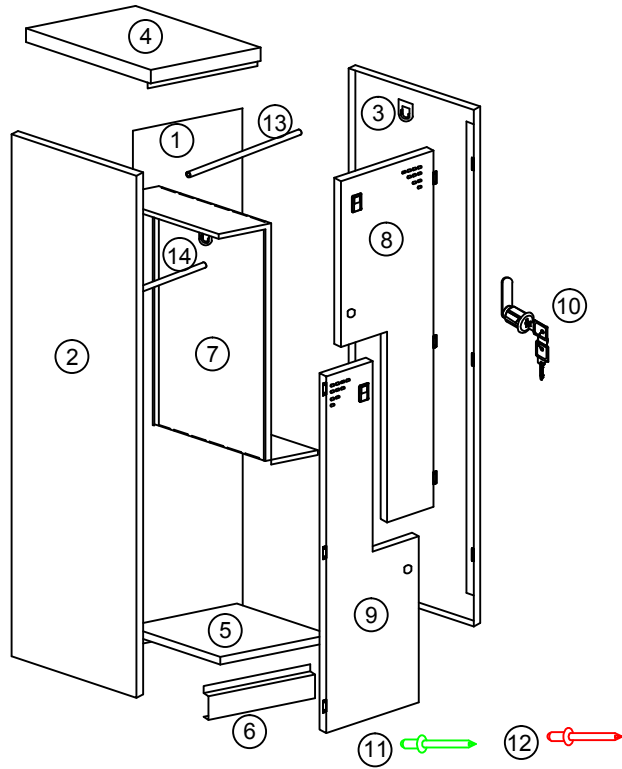

STEP-1

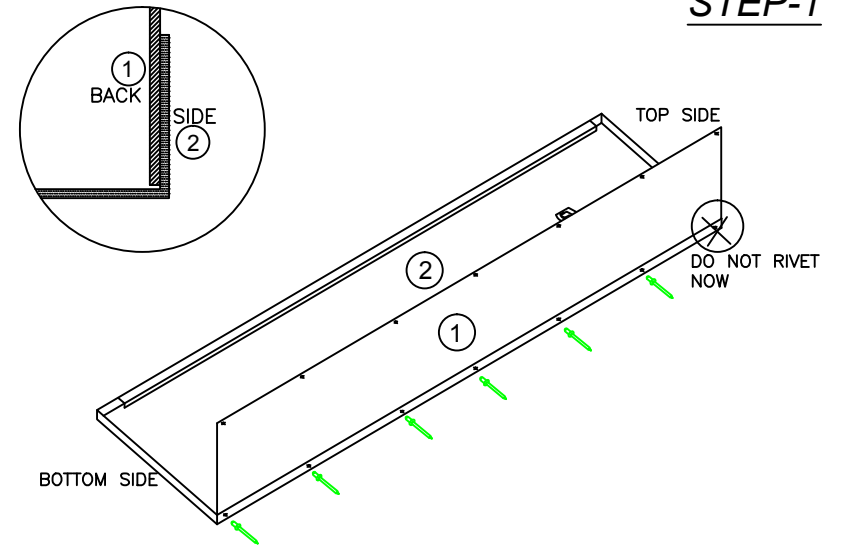

Place the LH Side Panel on the Flat surface(Assly Table) and rivet with the back panel as shown except the top hole (which will be riveted along with the Top panel) rivet from outside to inside.

STEP-2

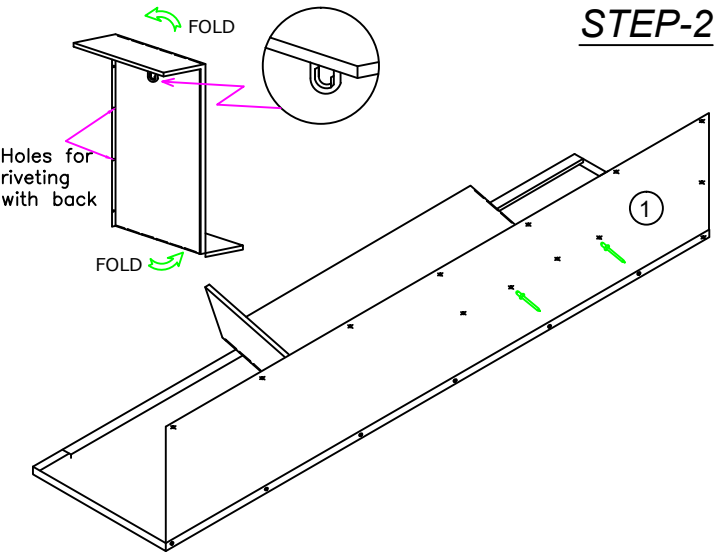

Bend the Partition (z Shelf as shown). ensure that the hanger pipe bracket comes on LH side

Rivet the Partition (z shelf) with the back panel as shown in the drawing (rivet from outside to inside)

STEP-3

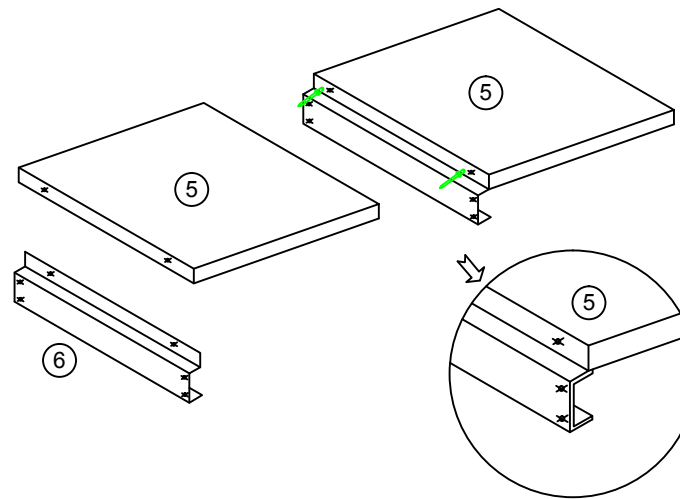

Insert the top flange of the bottom front into the bottom tray and rivet as shown in the drawing (separate sub assembly)

STEP-4

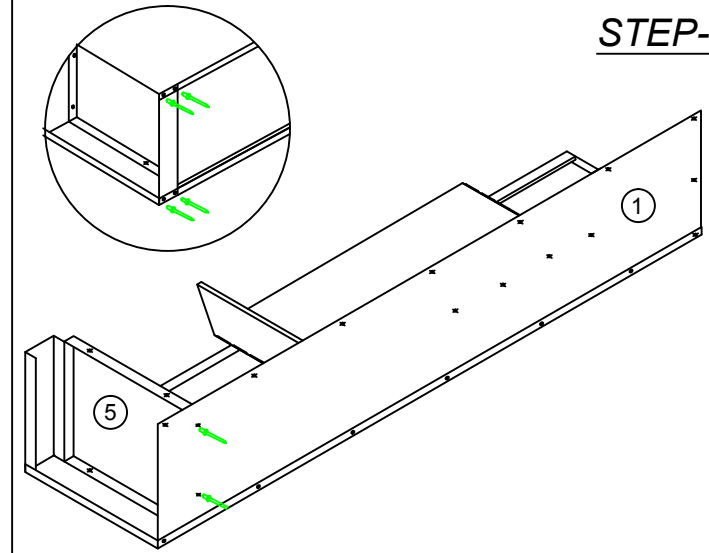

1. Rivet the bottom tray and bottom front assembly with the back panels as shown.
3. Rivet the bottom front with the side.

STEP-5

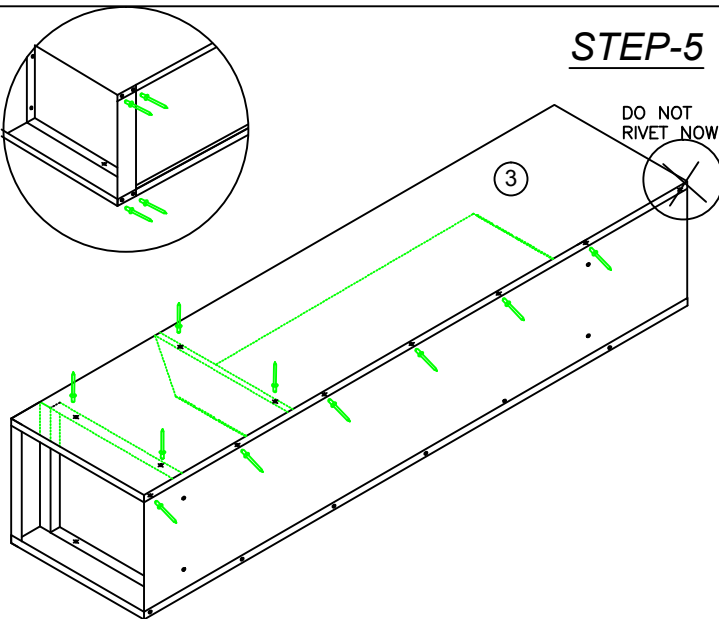

1. Place the RH side on Back, Partition (Z shelf) and Bottom tray assembly as shown.
2. Rivet the side with the back on all the holes except the top hole and also rivet the side with the Z SHELF and bottom tray as shown.

STEP-6

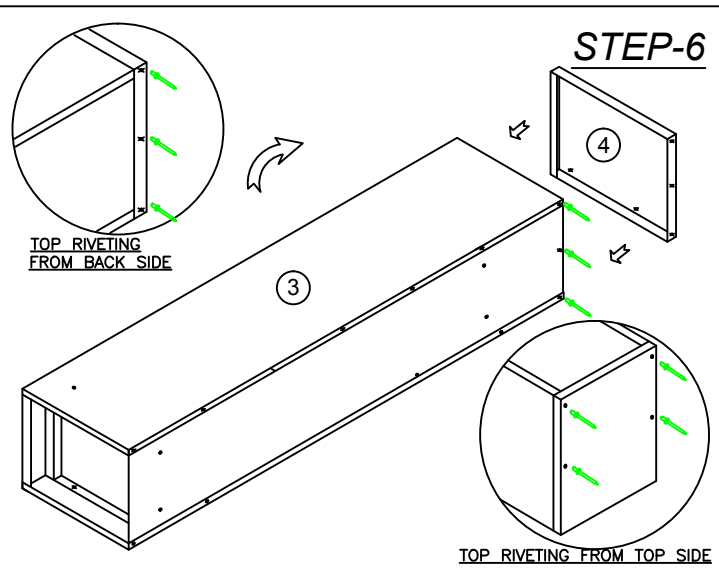

1. Fix the Top as shown and Rivet with the back and sides as shown.
2. Flip the Locker on Its back as shown (Back touches ground) for riveting the z shelf, Bottom tray with the LH Side.

STEP-7

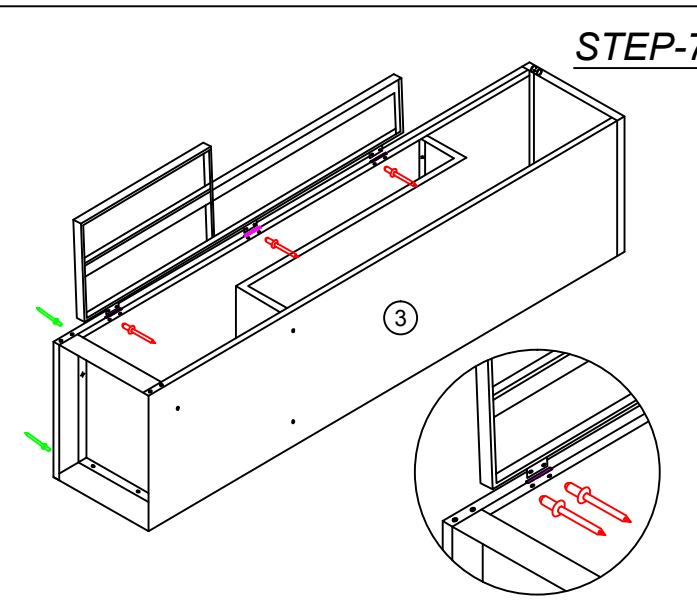

1. Rivet the LH side with the Partition (Z shelf) and the Bottom tray as shown.
2. Position the LH door Hinge in slots as shown and rivet with side using 4x8 counter sunk rivets.
3. Again Flip around the Locker on Its RH side for RH door (Top door) fixing.

Use 4x8mm Counter sunk Rivets for Door Fixing

STEP-8

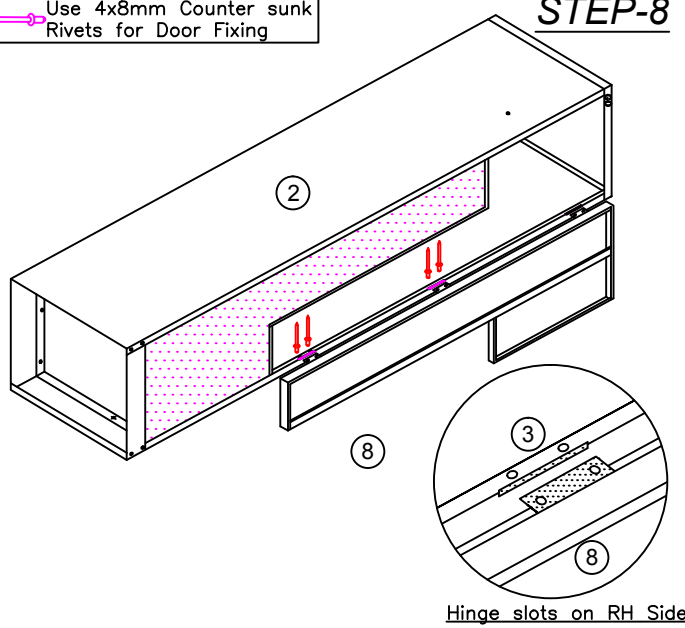

Position the RH door Hinges in slots as shown and rivet with side using counter sunk rivets and then lift erect the locker.

STEP-9

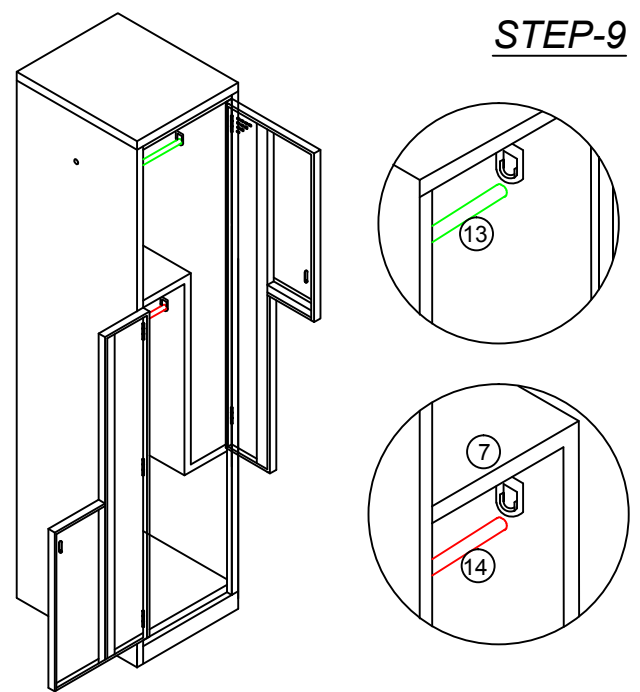

Fix the Coat rails (hanger rods) in both the compartments

STEP-10

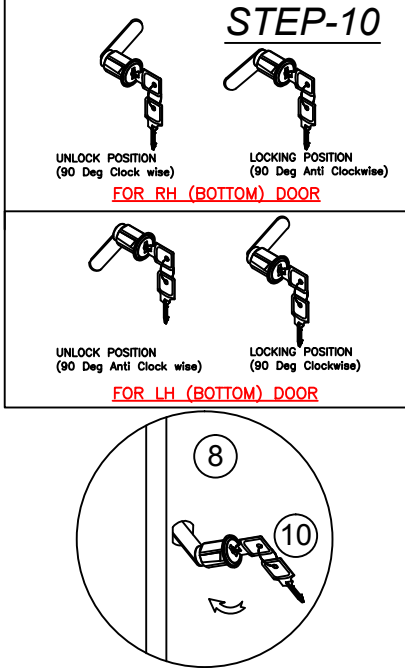
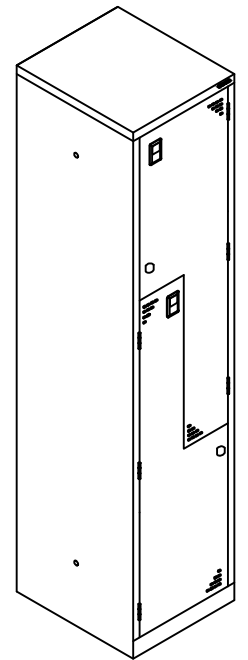

1. Check the lock for unlock and lock condition before fixing in hand.
2. Insert the lock in unlock condition and press completely as shown.