

# ASSEMBLY INSTRUCTIONS:

Product Code : RC5-O GW

Product Name: 5-O Reception Counter

## TIME REQUIRED:

60 minutes

## TOOLS REQUIRED:

Screwdriver, Electric Drill, Pencil, Measuring tape/Ruler

\*Tools are not included.

## SKILL REQUIRED:

Easy  Hard

The Assembly Skill Rating is a 5-point system that shows the degree of effort needed in assembling a specific product. With 1 being easy for the average person and 5 requiring an expert. For most products, two persons are recommended.

Please note, as this is a commercial product, some intermediate skills are required.

\*No pre-drill holes or markings are provided on tops.

### NOTE

- As this is a commercial product, some intermediate skills may be required.
  - No pre-drill holes or markings are provided on our table or desk tops.
  - Please check you have all hardware before assembling.
- If you are missing any hardware, please contact your Rapidline reseller. Please ensure you have the name of the item, required hardware part and quantity.
  - Please retain your receipt as proof of purchase to validate your warranty.
- Assemble on a clean, flat, smooth surface such as a rug or carpet to avoid parts from being scratched.
  - Remove all wrapping materials, including staples and packing straps before you start to assemble
    - Keep all hardware parts out of reach of children.

### CAUTION





- Heavy product. Do not attempt to lift or move without help
- Do not tighten screws and bolts until completely assembled.
- Do not use this product unless all bolts and screws are firmly secured and tightened.

### WARNING

- If parts are missing, broken, damaged or worn stop using the product until all repairs are made.
  - Failure to follow these warnings could result in serious injury.

# Assembly Instructions

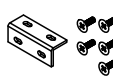
## MODEL NO.: RC2 RECEPTION DESK

<b>A</b>  46Set	<b>B</b>  46Pcs	<b>C</b>  26Pcs	<b>D</b>  4Set	<b>E</b>  Ø80 2Pcs
--	--	--	--	--

### STEP1

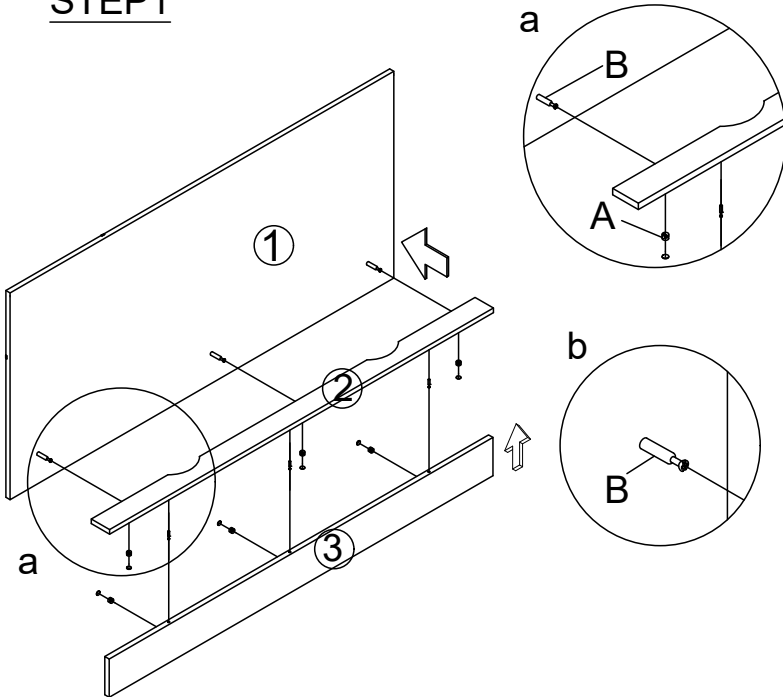

### STEP2

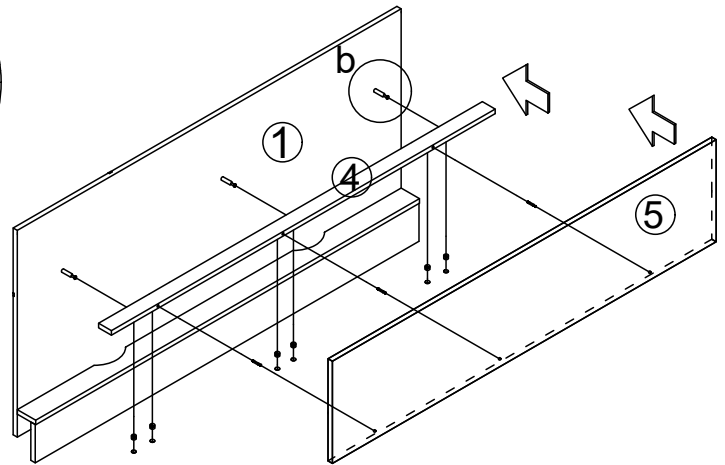

### STEP3

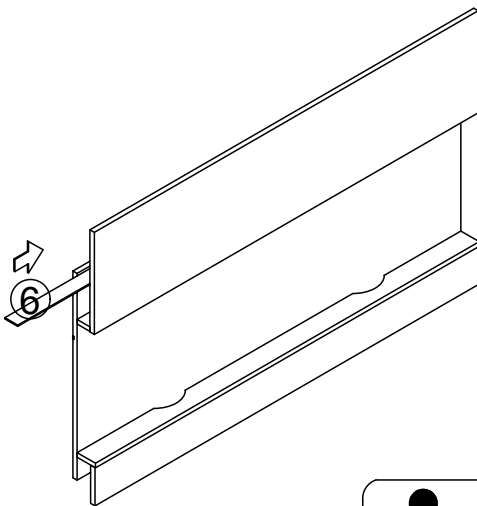

### STEP4

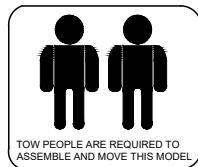
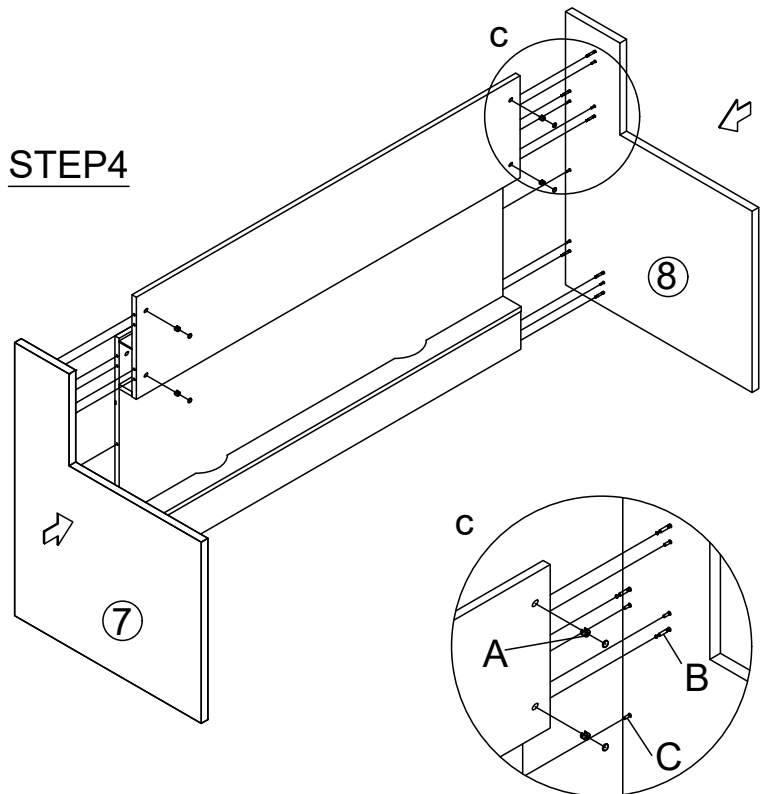

#### IMPORTANT NOTE:

- Place all parts on a clean and smooth surface such as a rug or carpet to avoid the parts from being scratched.
- Check to be sure that you have all parts and hardware.
- Remove all wrapping materials, including staples & packing straps before you start to assemble.
- Don't tighten all screws/bolts until all completely assembled.
- Keep all hardware parts out of reach of children

# Assembly Instructions

## MODEL NO.: RC2 RECEPTION DESK

### STEP5

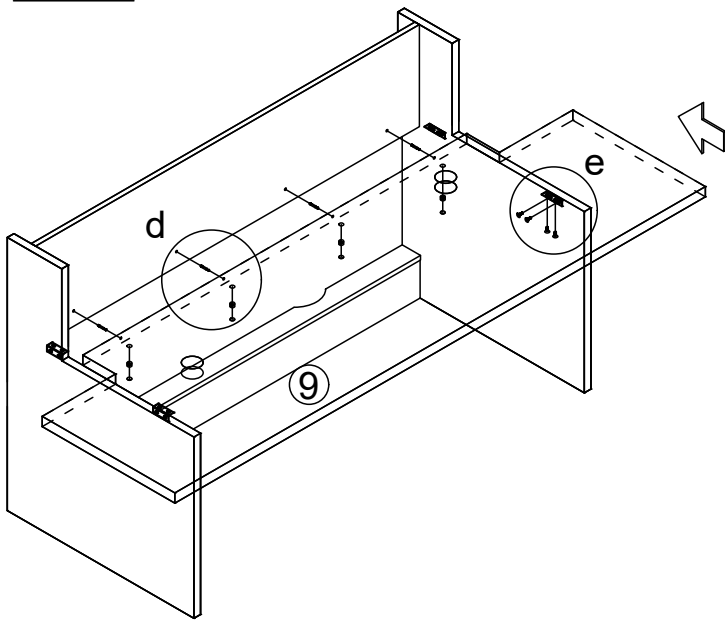

### STEP6

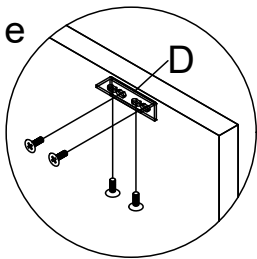
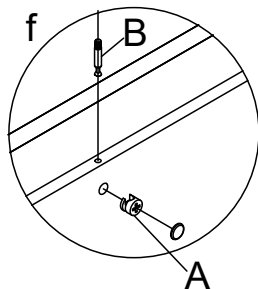
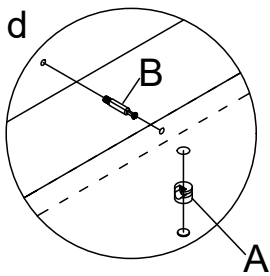
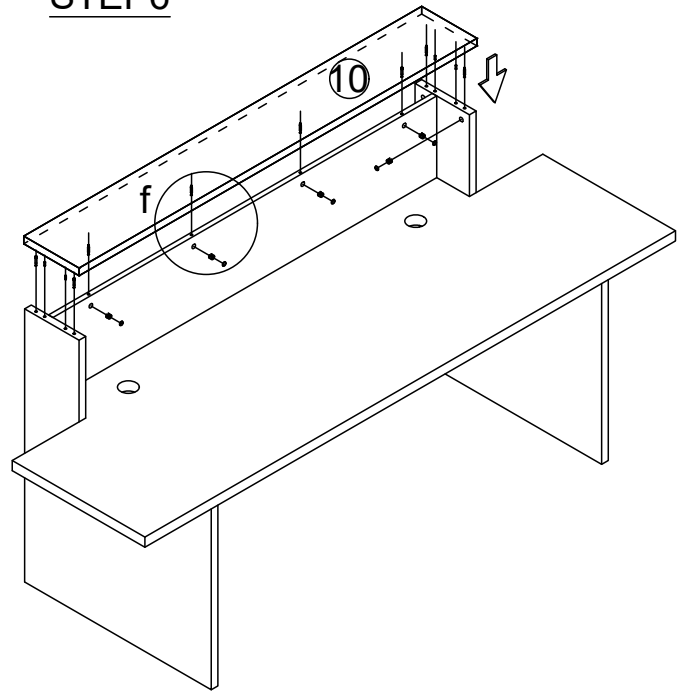

### COMPLETED ASSEMBLY

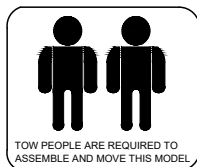
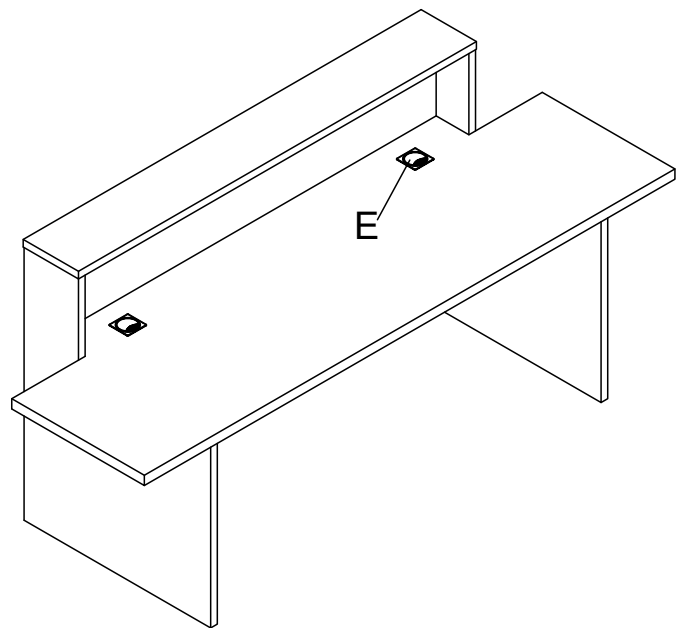

### IMPORTANT NOTE:

- Place all parts on a clean and smooth surface such as a rug or carpet to avoid the parts from being scratched.
- Check to be sure that you have all parts and hardware.
- Remove all wrapping materials, including staples & packing straps before you start to assemble.
- Don't tighten all screws/bolts until all completely assembled.
- Keep all hardware parts out of reach of children